

ZULJANA'S TOUCHSCREEN MONITOR ZL070TMBCAP

TOUCHSCREEN MONITORS - CUSTOM TOUCH SCREEN

Zuljana is among the most relied-on Touchscreen Monitors manufacturers with years of experience offering significant OEMs throughout all markets. Touchscreen monitors solutions are known for their performance in a few of the toughest applications.

Our sensors are customized to your one-of-a-kind application requirements based mainly on projected capacitive (PCAP) touchscreen monitors technology. BaoBao Industrial additionally supplies integration with custom touchscreen monitors LCD/OLED displays, cover lenses, and also peripherals.



Industrial Monitors Features

- ▶ Driver support for all the current operating syst
- ▶ A+ quality LED backlight panels
- ▶ 10-Finger-Multi Touch Capacitive Touch Panel
- ▶ Patented IP65 front with silicon seal
- ▶ The most common video connectors available
- ▶ High resolution LCD Panels
- ▶ Reinforced front glass
- ▶ 1 year guarantee



Ordering information

7"LCD,500 nits(Optional),3000:1,1024×768 pixels,24.60(H)×18.40(V),LED Backlight

IP Rating

IP65 Front / IP40 Back

LCD Panel

Screen Diagonal (Inch/cm)	7/17.78
Active Display Area(cm)	15.36(H)×9.00(V)
Aspect Ratio	16:9
Physical Resolution	1024×600
Maximum showable resolution	1920×1080
Colours Displayed	262K
Brightness (cd/m2)	500
Contrast	700:1
Typical Reaction Time Tr/ Tf (ms)	10/15
Visual Angle Horizontal / vertical (°)	150/145
Backlight/Backlight Lifetime (hours)	LED/20,000

Touch Panel

Touch Technology	Projected Capacitive 10-point Multitouch
Touch Panel Drivers	Windows; Linux; Mac; Android
Touch Life (Contacts)	Unlimited
Surface Hardness	7H
Surface Treatment	Anti-glare optional
Glass Strengthening	Tempered glass

Product Name

7"Capacitive Touch Monitor

Model Number

ZL070TM8CAP

Operation/Mechanical

Operating Temperature (°C)	-10~+60
Humidity Range (RH)	10%-90%
Net Weight(Kg)	1.20
Gross Weight(Kg)	2.20(Incl.cartonage)
Housing Material	Aluminum front/back case
Housing(mm)L x W x H	30.86 × 23.91 × 3.78
Mounting	VESA 100

External Connectors

Video	1×HDMI 1.3 (Incl.HDCP) 1 × DVI-D 1 × VGA
Audio	1×PC-Audio
Touch Connector	1×USB
Connectors	1×12V DC-IN

Power

Power Indicator	Green LED
Power Supply	100-240V ACDC Active Switching;12V DC-Out
Working Power (V)	12
Working Power (w)	12
Stand-By Consumption	<1

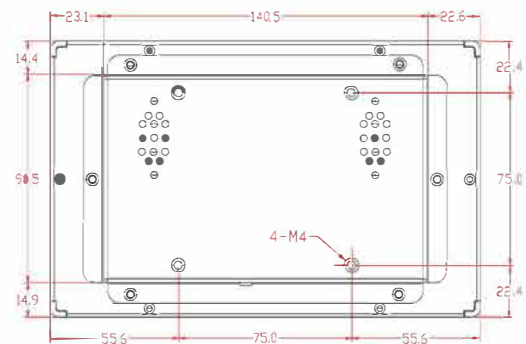
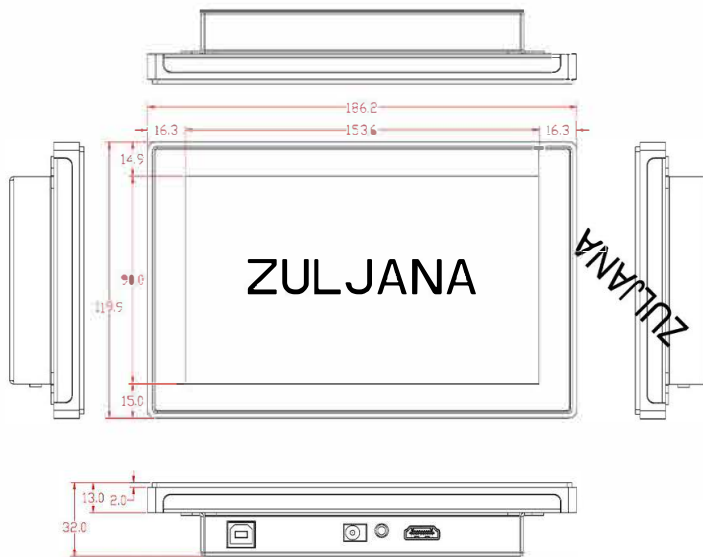

Learn more about Zuljana at baobao-industries.com

- +86 755 23775660
- +86 755 23779143
- sales@baobao-industries.com
- <http://www.baobao-industries.com>

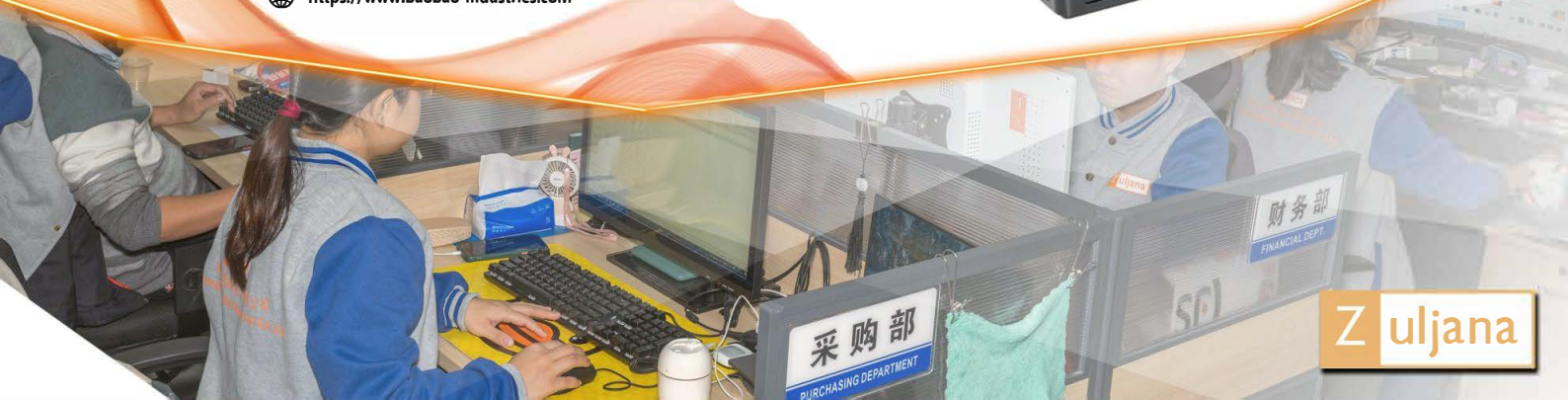

Zuljana